

Vanguard™ 355-2500

QUASI-CW DPSS 2.5 W UV LASER

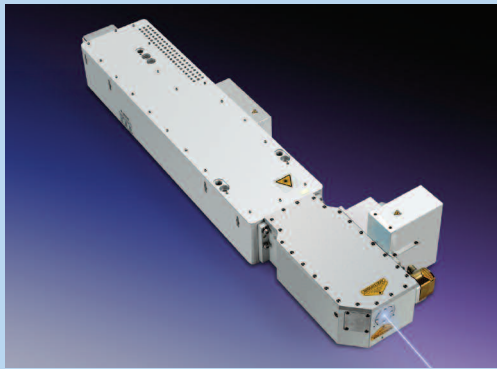

The Vanguard 2.5 W Advantage

- Rugged industrial platform
- Outstanding beam performance and power stability
- Closed-loop power control
- Near diffraction limited TEM₀₀ output
- RS 232 interface for system control and diagnostics
- Hands off, motorized control via RS 232 to simplify preventative maintenance
- On-board data log of all key functional parameters
- Low maintenance power supply
- Extreme long-life diode
- Dependable supply chain and local worldwide service support

The Spectra-Physics® Vanguard™ 355-2500 is a state-of-the-art DPSS laser specifically designed to produce exceptionally reliable quasi-CW UV output. This rugged OEM laser uses advanced mode-locking technology to deliver 2.5 W of picosecond pulses at 355 nm with low noise and excellent TEM₀₀ mode quality.

The Vanguard 355-2500 laser features high stability beam characteristics and low cost of ownership necessary for a variety of OEM applications. Designed for the stringent demands of semiconductor wafer processing, the Vanguard 355-2500 is also ideal for a wide range of micro-material processing applications.

The Vanguard series of lasers are field proven with over 1,000 systems in tough 24/7 operations. Every feature on the Vanguard 355-2500 laser is designed for these conditions. The system can be remotely controlled via RS 232 interface, and incorporates extensive on-board data logging of key parameters. Closed-loop power control ensures consistent UV output power to less than 2% variation from specified level. Hands-off, motorized control of the THG crystal and Saturable Absorber Mirror (SAM) increases ease of use, and extends the Vanguard laser's operational life. The diode module is a proprietary design for exceptionally long life, and is located remotely in the power supply, enabling easy replacement without laser head alignment.

Newport and Spectra-Physics control the production of all key elements: SAM, optical substrates, coatings, power supply and fiber-coupled diodes. Each component has been designed in-house and tightly controlled through our supply chain. In addition, OEMs requiring high uptime and consistent performance over a long life have the assurance of the Spectra-Physics Vanguard 355-2500. World-class field service and expert technical support come standard from the global leader in photonics.

APPLICATIONS

- Wafer inspection
- Laser direct imaging
- Solar cell processing
- Polyimide cutting and drilling
- LED processing
- Glass cutting
- Various micro-material processing

Vanguard™ 355-2500

Specifications

General Characteristics¹

Wavelength	355 nm
Power	2.5 W
Repetition Rate	80 MHz ±2
Pulse Width ²	<12 ps

Beam Characteristics

Spatial Mode	TEM ₀₀
M ²	<1.2
Far Field Divergence, full angle	<1 mrad
Beam Diameter (1/e ²)	1.0 mm nominal
Beam Pointing Stability	<25 mrad/°C
Beam Beam Ellipticity	<20% far field
Average Power Stability ³	<2%
Amplitude Noise	<1% rms, 10 Hz to 2 MHz
Polarization Ratio	>100:1 vertical

Operating Conditions

Cold Turn-on Time (AC off to full power)	<30 min
Cold Turn-on Time (AC off to full specs)	<1 hr
Temperature Range	20–27°C

Utilities

AC Input	100–240 VAC ±10%, 50–60 Hz
Power Consumption	<1000 W (500 W typical)
Cooling Requirements	Re-circulating water chiller (100 W capacity, nominally 20°C at 2.7 l/min), Additional electrical power required.

1. Due to our continuous product improvement, all specifications are subject to change without notice.
2. Contact Spectra-Physics for other repetition rates.
3. Interpolated from measurements of the fundamental 1064 nm pulse. A sech² (0.65 deconvolution factor) shape is used to determine the 1064 nm pulse width as measured with Spectra-Physics model 409 autocorrelator.
4. Percentage power drift in any two-hour period with less than ±2°C temperature change after a one-hour warm up.
5. Recirculated chiller water can tighten pulse repetition rate tolerance (contact Spectra-Physics for further guidance.)

Vanguard 355-2500 Dimensions

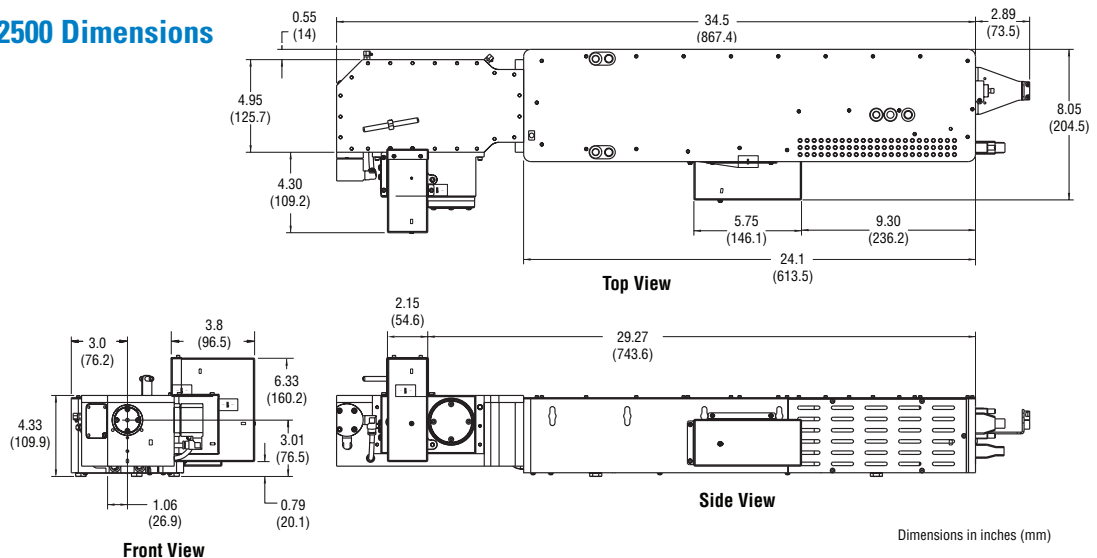

3635 Peterson Way, Santa Clara, CA 95054, USA

PHONE: 1-800-775-5273 1-408-980-4300 FAX: 1-408-980-6923 EMAIL: sales@spectra-physics.com

www.newport.com/spectra-physics

	PHONE	EMAIL		PHONE	EMAIL
Belgium	+32-(0)0800-11 257	belgium@newport.com	Irvine, CA, USA	+1-800-222-6440	sales@newport.com
China	+86-10-6267-0065	china@newport.com	Netherlands	+31-(0)30 6592111	netherlands@newport.com
France	+33-(0)1-60-91-68-68	france@newport.com	United Kingdom	+44-1235-432-710	uk@newport.com
Japan	+81-3-3794-5511	spectra-physics@splasers.co.jp	Germany / Austria / Switzerland	+49-(0)6151-708-0	germany@newport.com
Taiwan	+886-(0)2-2508-4977	sales@newport.com.tw			

Newport Corporation, Irvine and Santa Clara, California and Franklin, Massachusetts; Evry and Beaune-La-Rolande, France; Stahnsdorf, Germany and Wuxi, China have all been certified compliant with ISO 9001 by the British Standards Institution.

Newport Corporation, Global Headquarters PHONE: 1-800-222-6440 1-949-863-3144
1791 Deere Avenue, Irvine, CA 92606, USA EMAIL: sales@newport.com

Complete listings for all global office locations are available online at www.newport.com/contact

© 2010 Newport Corporation. All rights reserved. Spectra-Physics, the Spectra-Physics logo and the Newport logo are registered trademarks of Newport Corporation. Vanguard is a trademark of Newport Corporation.

DS-041002 (08/11)